

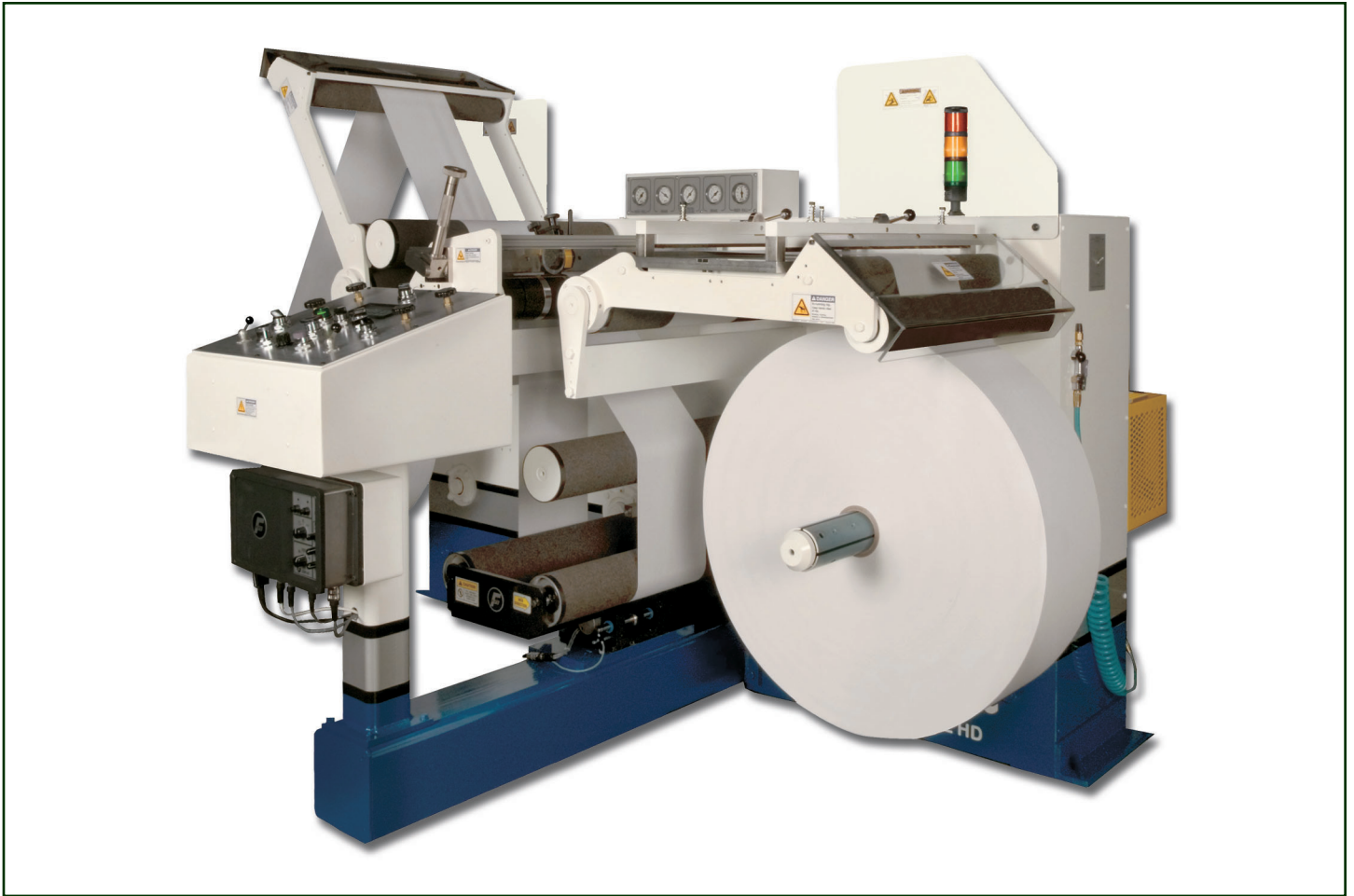

Doctor Machine® Model 152 HD



Key Features

- Cantilevered design
- Reversible winding
- Automatic tension control
- 1/2 - 1 1/2 PLI (0.875 to 2.627 N/cm)
- Automatic web guide
- Air operated rider rolls
- 20" (508 mm) web width; Wider web-widths available
- 40" (1016 mm) unwind and rewind diameters; Larger diameters available
- 1500 FPM (457 m/min) operation
- 900 lb (408 kg) roll weight
- Heavier roll options available
- Razor or shear trimming

Barry-Wehmiller

ACCRAPLY®

ACCRAPLY®

Stanford

Trine

Graham

Doctor Machine®

Model 152 HD

The Stanford Model 152 HD Reversible Doctor Machine® provides an efficient method of splicing and removing defective printing while maintaining print direction.

The reversing feature on this heavy duty rewinder reduces roll salvaging time. In one cycle, an operator can unwind to the defect, make the necessary correction and reverse wind to maintain the print pattern.

The Model 152 HD accommodates a wide range of materials including non-extensible films; paper, film, and foil laminates; and pressure sensitive stock.

Accraply engineers the world's largest selection of Doctor Machines®, as well as a complete line of duplex differential slitter rewinders and shrink sleeve finishing equipment.



Stanford Sales Office
 1139 South Broadway
 Salem, IL 62881 USA
 +1 (618) 548-2600

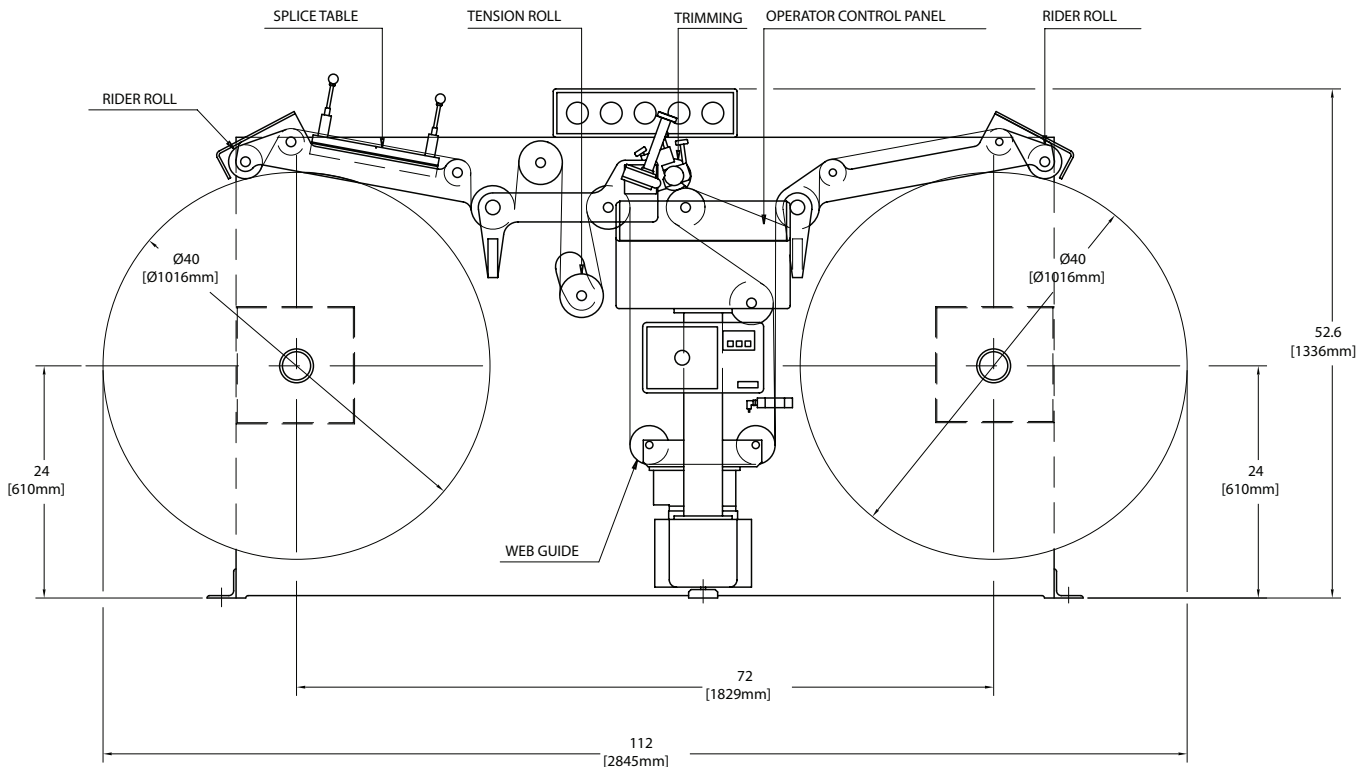

Accraply, Inc.

A BARRY-WEHMILLER COMPANY

3580 Holly Lane North, Plymouth, MN 55447-1269 USA • +1 (763) 557-1313
 sales@accraply.com • www.accraply.com