

ACCRAPLY®

Doctor Machine® Model 152 jr



Key Features

- Reversible winding
- 10" (254 mm) web width; Other web-width options available
- 3" (76.2 mm) and/or 6" (152.4 mm) pneumatic unwind and rewind shafts
- 1500 fpm (457 m/min) operation
- 200 lb. (90.7 kg) roll weight
- Automatic web guide
- Automatic tension control
- Splice table
- Touch screen control with a two-motor AC Vector drive system
- 1/4 - 1/2 PLI (0.438 - 0.875 n/cm)
- Razor or shear trimming
- Free web span available for roll inspection
- Air-operated rider rolls for density control
- Label inspection/bar-code verification systems available as an option

Barry-Wehmiller

ACCRAPLY®

ACCRAPLY®

Stanford

Trine

Graham

Doctor Machine®

Model 152 jr

Designed specifically for the narrow-web market, the Model 152jr is capable of winding a wide range of products from light gauge extensible films to pressure sensitive label stock.

This reversible rewinder utilizes the latest in drive and control technology making it capable of a tension range from 1/4 to 1/2 PLI. The Model 152jr can be equipped with a range of label detection/inspection options capable of counting labels, identifying missing labels, and verifying all standard bar-code formats.

Accraply engineers the world's largest selection of Doctor Machines®, as well as a complete line of duplex differential slitter rewinders and shrink sleeve finishing equipment.



Stanford Sales Office
 1139 South Broadway
 Salem, IL 62881 USA
 +1 (618) 548-2600

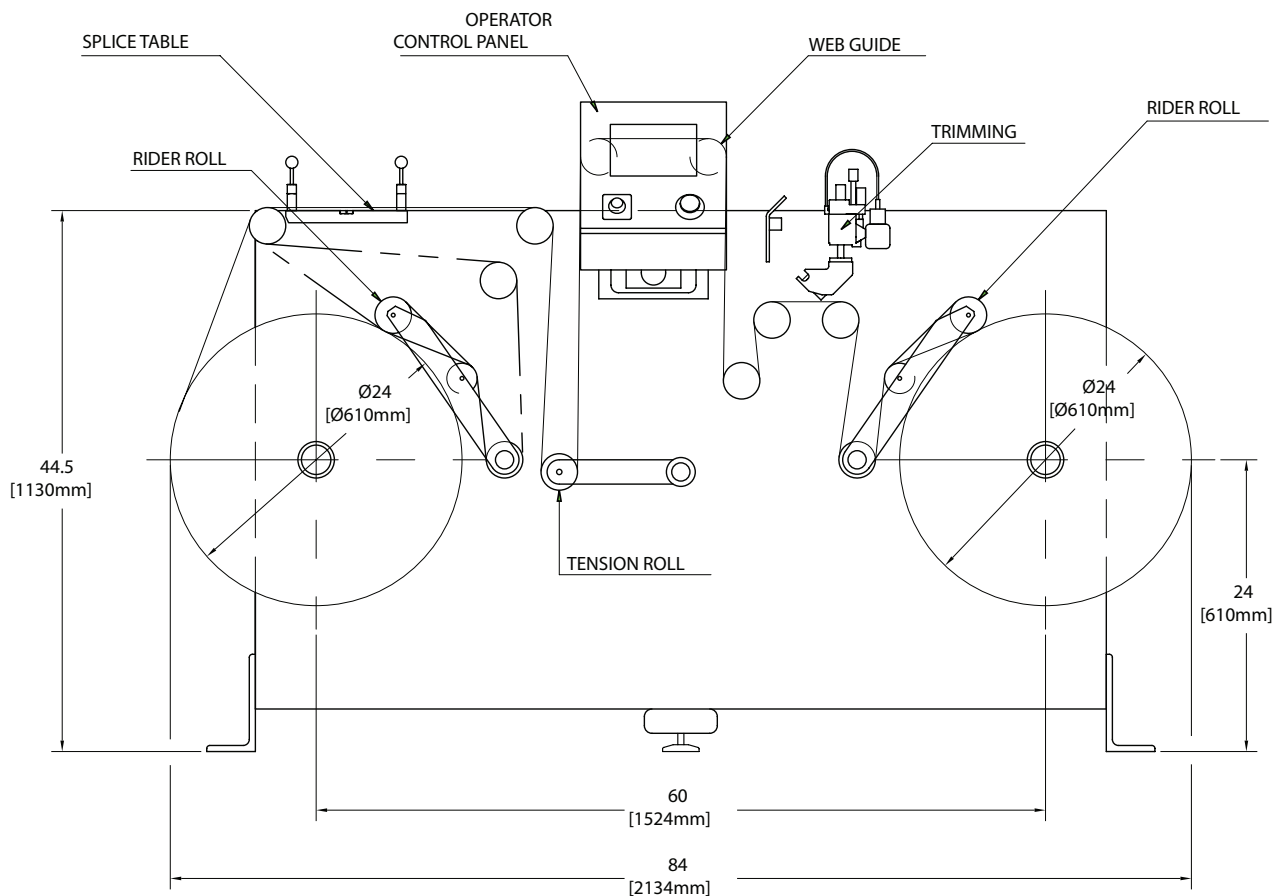

Accraply, Inc.

A BARRY-WEHMILLER COMPANY

3580 Holly Lane North, Plymouth, MN 55447-1269 USA • +1 (763) 557-1313
 sales@accraply.com • www.accraply.com