



Slitter Rewinder

Model 3038 | Model 3038 HC



Key Features

- Web widths 62" (1575 mm) to 70" (1778 mm). Wider options available.
- Rewind diameters 24" (610 mm) and 32" (813 mm)
- Speeds up to 1500 fpm (457 m/min) or 2000 fpm (610 m/min)
- Unwind diameter 40" (1016 mm) standard; 50" (1270 mm) optional
- Pneumatic shear, razor or score slitting
- Rider roll for density control
- Automatic web guide and tension control
- Touch screen controls

Barry-Wehmiller

ACCRAPLY

ACCRAPLY

Stanford

Trine

Graham

Slitter Rewinder

Model 3038 | Model 3038 HC

The Stanford Models 3038 and 3038 HC performs well on a range of materials including all films, laminates, papers, non-woven, vinyl, cellophane and pressure sensitive materials.

All Stanford Slitter Rewinders are proven performers with a robust construction that offers years of dependable service. Accraply will customize equipment to meet customer-specific requests.



Stanford Sales Office
 1139 South Broadway
 Salem, IL 62881 USA
 +1 (618) 548-2600

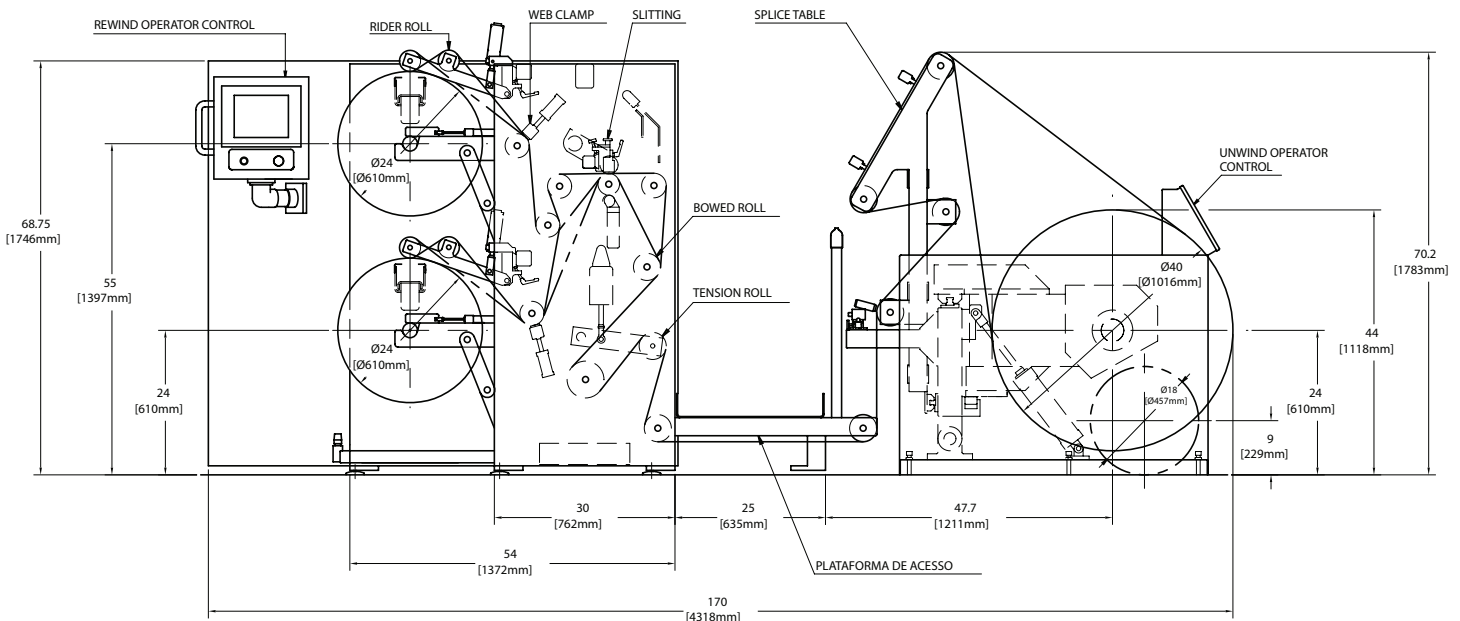

Accraply, Inc.

A BARRY-WEHMILLER COMPANY

3580 Holly Lane North, Plymouth, MN 55447-1269 USA • +1 (763) 557-1313
 sales@accraply.com • www.accraply.com