

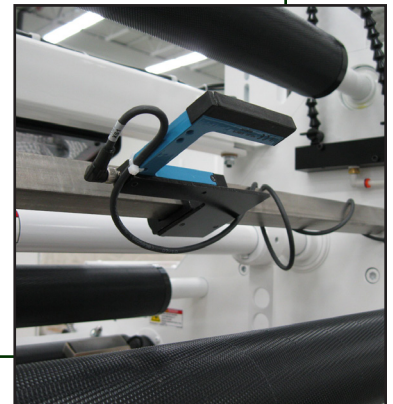

Doctor Machine® Inspector

Model DM10 | Model DM12 | Model DM16



Key Features

- Reversible
- Over/under winding
- Standard web-widths of 10” (254 mm), 12” (305 mm), 16” (406 mm)
- Faster running speeds – up to 1640 fpm (500 mpm)
- Unwind and rewind roll diameters of 24” (610 mm)
- Touch screen controls with two-motor AC Vector drive system

Barry-Wehmiller



**Doctor Machine® Inspector**

**Model DM10 | Model DM12 | Model DM16**

Designed specifically for shrink-sleeve applications, the Model DM 10, DM12, and DM16 compliment Stanford's Seamachine. With seam inspection options ranging from manual to automatic, the Doctor Machine Inspector series of rewinders offers operators unparalleled control and inspection capabilities.



**Stanford Sales Office**  
 1139 South Broadway  
 Salem, IL 62881 USA  
 +1 (618) 548-2600

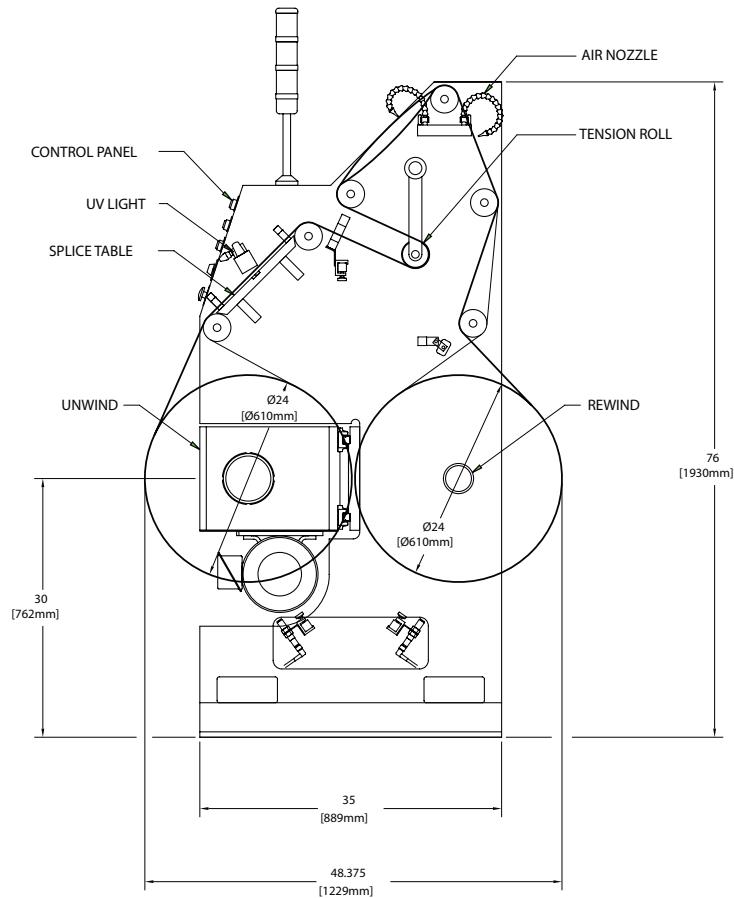

**Accraply, Inc.**

A BARRY-WEHMILLER COMPANY

3580 Holly Lane North, Plymouth, MN 55447-1269 USA • +1 (763) 557-1313  
 sales@accraply.com • www.accraply.com