



Model 35W "S" Series



Features

- Heavy-duty construction utilizes oversized drive components combined with an aluminum stainless steel base frame for years of dependable service
- Adjustable variable speed conveyor
- Quick "no-tools" adjustments with position indication for fast, repeatable changeover
- Various product infeed systems available that produce precise product spacing for your applications
- Centrally driven wrap-belt for constant speed synchronization
- Quick-change wrap-belt assemblies for labeling within a recess or beneath oversize caps
- Advanced high torque servo driven applicators include ratio-offset and speed-following capability for accurate and reliable application of a wide variety of label materials
- Drop-in-from the top label threading web path with quick-release rewind reel core
- Convenient centralized pivoting touch-screen
- Operator interface controls

Model 35W "S" Series High Speed Wraparound Labeling System

The Accraply Model 35W "S" Series is an extremely versatile labeling system designed for the application of wraparound labels on a wide range of cylindrical containers.

Rugged construction for demanding continuous-duty operation; quick, easy changeover capability from one product to another; and proven technology make this system an exceptional value. All specifications and tooling requirements are subject to Accraply evaluation of all label and product samples. Specifications below reflect standard machine capabilities. Accraply can also meet other specification requirements. Please call for details.

Options

- Hot stamp printer or various other printers
- Wide web label capacity
- Infeed metering wheel or quick-change feed screw
- Various width wrap assemblies
- Clear film label sensor
- Infeed and outfeed product backlog sensor
- Conveyor extensions
- Large capacity powered rewinds and unwinds
- Inspection options

Application Rate	Up to 3000" per minute
Production Rates	Up to 600 per minute depending on product and label sizes
Electrical Requirements	220VAC, 3-Phase, 60 Hz, 20 Amp Service
Applied Accuracy	+/- 1/32" (1 mm)
Air Requirements	80 PSI
Product Conveyor	4.5" wide flush sided
Product Capacity	Maximum Diameter: 8" Maximum Height: 12.5" Minimum Diameter: .75" Minimum Height: 1.75"
Label Capacity	Maximum Length: 20" Maximum Height: 6" Minimum Length: .75" Minimum Height: .375"

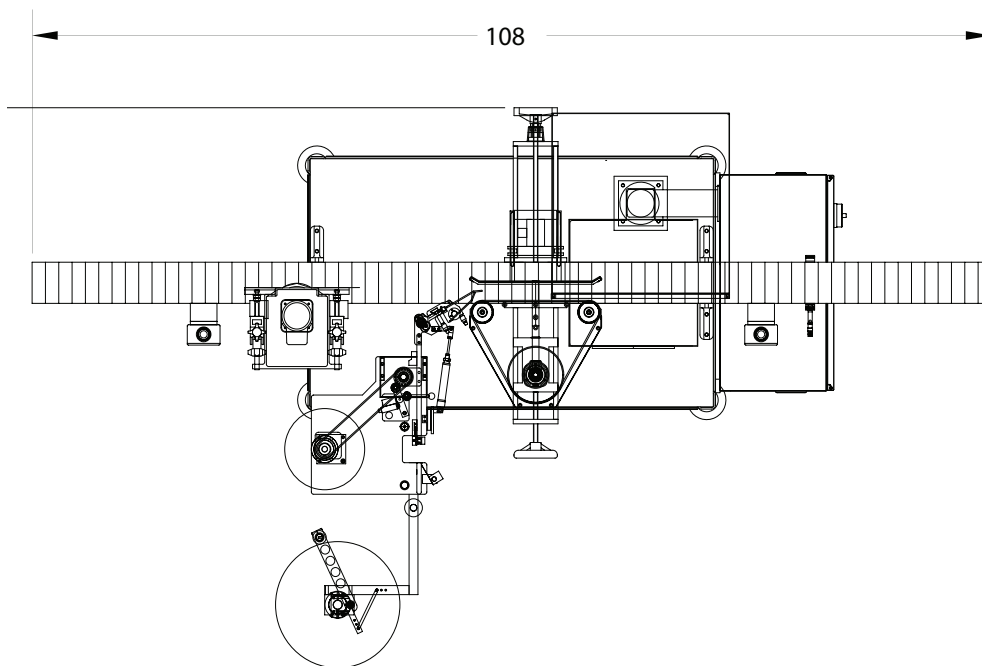

Accraply

Trine

Stanford

Graham

Sleevit

Harland

BW Packaging Solutions consist of Accraply, BW Container Systems, Design Group, Paper Converting Machine Company, Pneumatic Scale Angelus, Thiele Technologies and Synerlink. Through their diverse capabilities, these companies can collectively provide everything from a single piece of equipment to fully integrated, tailor-made packaging line solutions for a wide range of industries, including: food and beverage, personal care, container manufacturing, pharmaceutical and medical devices, household products, paper products and textiles, industrial and automotive, and converting, printing and publishing.

BWPackagingSolutions.com

barrywehmiller

 betterworld