

Stanford 142HD Doctor Machine®



Features

- Cantilevered design eases operation without the need to handle shafts
- Automatic tension control
- Rider roll for density control
- Automatic web guide
- Bowed roll for web separation after slitting
- AC Vector drive system
- Web break detection
- Programmable stop and early stop length
- Pneumatic trimming

Stanford 142HD Doctor Machine®

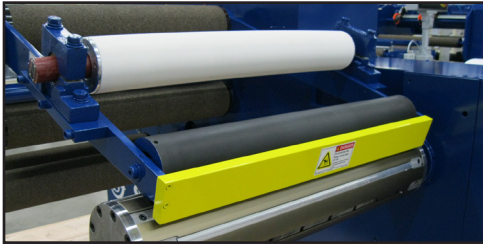

The Original Heavy-Duty Doctor Machine@...

the Stanford 142HD provides an efficient method of salvaging defective material. Doctoring capabilities include the correction of telescoped rolls, removing defective stock, repairing splices, re-tensioning loose rolls, edge trimming and butt roll rewinding.

The range of materials easily handled by this model includes papers, self-adhesive label stock, polystyrene and stable film laminates.

Accraply engineers a large selection of Stanford Doctor Machines®, a complete line of duplex differential slitter rewinders and shrink sleeve finishing equipment, as well as customized equipment.

Minimum Web Width	4" [102 mm]
Maximum Web Width	24" [610 mm]
Maximum Web Speed*	1,500 fpm [457 mpm]
Maximum Unwind Diameter	42" [1,067 mm]
Maximum Roll Weight	500 lbs [227 Kg]
Maximum Rewind Diameter	42" [1,067 mm]
Tension	1.5 PLI [0.26 Kg/cm]
Total Minimum Tension	12 lbf [6.2 Kgf]
Trimming Options	Razor Shear
Machine Options	Static Elimination Strobe

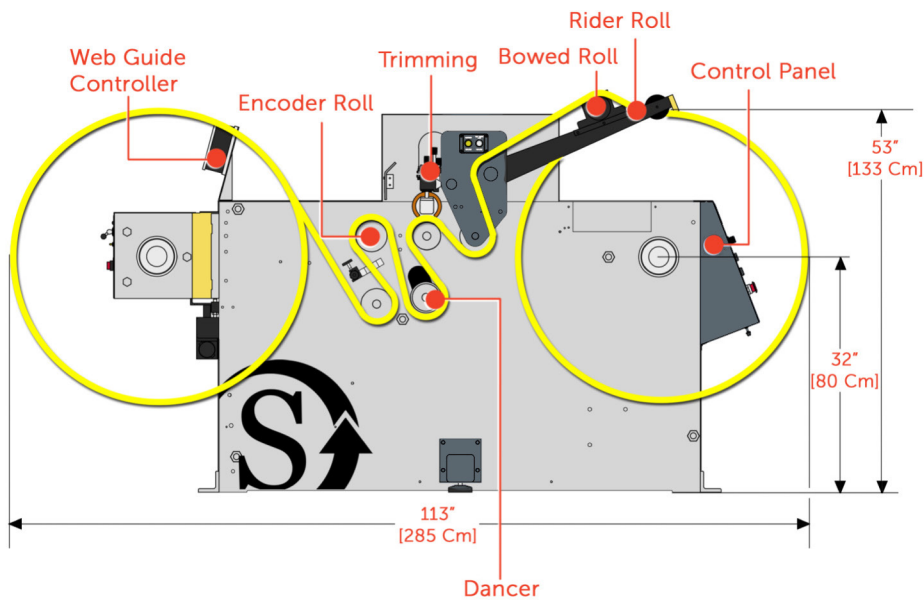

Accraply's Gold Standard of Service

"We commit to deliver the highest level of customer care driven by our passion to provide the best customer experience in everything we do."

Accraply | Trine | Stanford | Graham & Steevit | Harland

Accraply

9350 W Broadway Avenue, Suite 190
Minneapolis, MN 55445 USA

+1 (763) 557-1313
accraply.com

