

2xx Series Label Applicator

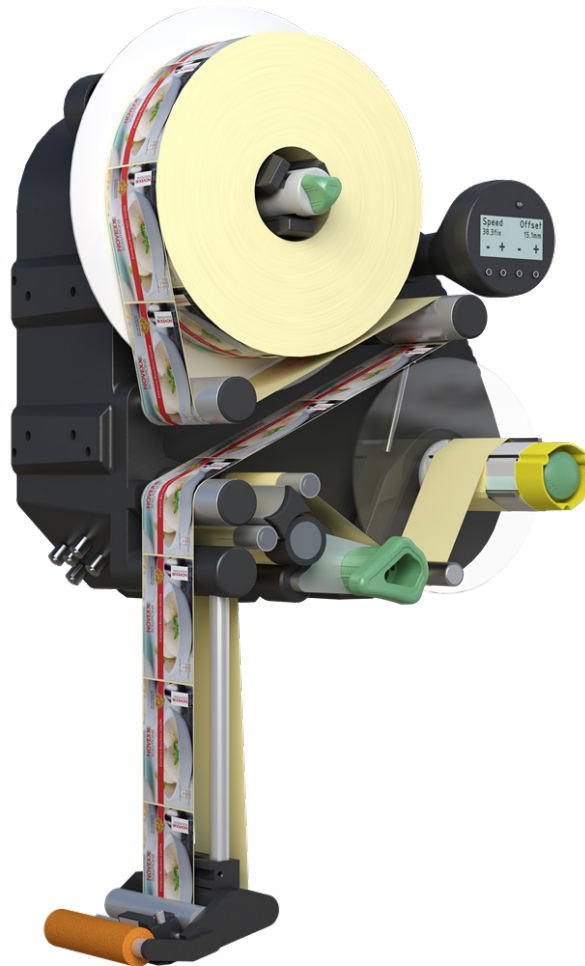

Features

- Large display with intuitive menu navigation
- Built-in features for high productivity
- Compact shape for easy integration with existing packaging equipment
- Supports a wide variety of label applications
- Fast, flexible, user-friendly
- Reliable and accurate
- Robust, industrial frame and components for low maintenance and long life
- Designed for demanding, 24/7 use
- Backed by Accraply's "Gold Standard of Service"

Accraply 2xx Series Pressure Sensitive Label Applicator

For over 45 years Accraply has designed, engineered and built high quality labeling systems to help our customers meet their labeling demands.

The 2xx series of labelers combine a tough, rugged design with high performance electronics and drives to tackle the most demanding applications. They can be easily integrated with existing packaging equipment, used as stand-alone portable labelers or supplied with one of our product handling systems to suit your specific requirements.

These modular concept labelers offer the flexibility to run many types of pressure sensitive labels including thin films, clear films, hang-tabs, sensormatic/checkpoint tags, coupons and booklet style labels.

Features

- 300mm/12" diameter label roll unwind with advanced label liner tension control
- Stepper drive with dual nip rollers for precise and consistent label feed
- Independently driven, collapsible rewind for quick, easy removal of the waste liner
- Microprocessor with built-in applicator controls, auto diagnosis and status messages
- Integrated redundant label applicator control for non-stop label roll changes
- Automatic product speed following (requires optional shaft encoder)
- Ethernet connection for remote monitoring, troubleshooting and set-up
- USB port to backup set-up parameters to a flash drive

Options

- Blow-on, Tamp-Blow, Swing-Arm & Corner-Wrap Applicators
- Shaft Encoder for automatic speed following
- Remote operator interface
- Label coders such as SmartDate or DataFlex thermal transfer printers
- Ultrasonic label sensor for clear labels
- Alarm package with three color light stack
- Kits to run Hang-Tabs, Checkpoint or Sensormatic tags
- IP65 rating for wet or dusty environments
- Custom engineered product handling solutions

Accraply's Gold Standard of Service

"We commit to deliver the highest level of customer care driven by our passion to provide the best customer experience in everything we do."

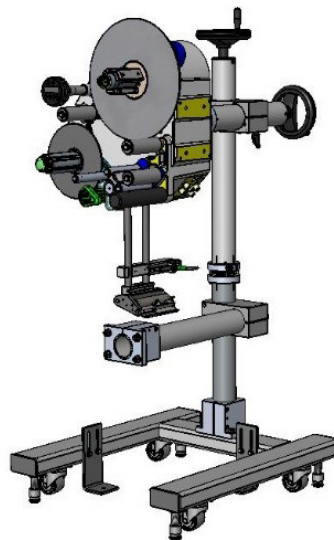

Accraply is a leader in the design, manufacture, and support of automated label application systems as well as converting and finishing equipment for the shrink sleeve label and flexible packaging markets.

204

Application Rate	40 meters (1,575") per minute
Web Width	10 - 110 mm (.39" - 4.33")
Label Length	5 - 600 mm (.19" - 23.6")

206

Application Rate	30 meters (1,181") per minute
Web Width	10 - 160 mm (.39" - 6.29")
Label Length	5 - 600 mm (.19" - 23.6")

209

Application Rate	25 meters (984") per minute
Web Width	50 - 233 mm (1.9" - 9.17")
Label Length	5 - 600 mm (.19" - 23.6")

256

Application Rate	50 meters (1,968") per minute
Web Width	10 - 160 mm (.39" - 6.29")
Label Length	5 - 600 mm (.19" - 23.6")

272

Application Rate	70 meters (2,755") per minute
Web Width	10 - 53 mm (.39" - 2")
Label Length	5 - 600 mm (.19" - 23.6")

General Specifications

Label Stop Accuracy	+/- 0.5 mm (0.019") When running at fixed speed +/- 1 mm (0.039") When speed following
Label Rolls	O.D. 300 mm (12") Core: 76.2 mm (3")
Electrical	110VAC, 50/60HZ, 4A 240VAC, 50/60 HZ, 2A
Weight	40 Kg (88 lbs) approximately
Operating Temp.	5 - 40 C (41 - 104 F)
Humidity	30 - 85% non-condensing
Certifications	CE, TUV/GS, FCC, NRTL (US/CA), EAC
Noise Level	<70 dB for the standard wipe-on applicator

Accraply | Trine | Stanford | Graham & Sleevit | Harland

Accraply

9350 W Broadway Avenue, Suite 190
Minneapolis, MN 55445 USA

+1 (763) 557-1313
accraply.com