

350B Bottom and/or Top Labeler



Features

- Heavy gauge stainless-steel base frame with adjustable leveling feet and heavy duty casters
- Adjustable variable speed dual side belt conveyor for greater product control
- Centralized system control panel with CTC color touch-screen, product and label counters, and rate meter
- Convenient, centralized pivoting operator interface
- controls with stack light
- Available with either stepper applicators (as shown) or servo applicators
- No-tools adjustments and change parts with integral position reference indicators
- Drop-in label threading with quick release rewind reel core

350B Bottom and Top Panel Labeler

The Accraply Model 350B is a special purpose labeling system developed specifically to apply top and bottom panel labels to a wide variety of products.

The Model 350B is a complete system which includes an adjustable speed dual side belt product transport conveyor for optimum product throughput and control. It also has an easy access label applicator for accurate and consistent label placement and a centralized system control panel. Accraply utilizes a heavy gauge welded stainless-steel base frame to provide rigid support for all product handling and labeling components.

Options:

- Print and apply label applicators
- Wide web label capacity
- SSTL peeler tips
- Applicator convenience package including low label roll and broken web alarms
- Clear label sensors
- Hot stamp date coder
- Hot stamp date coder convenience package including low ribbon and broken ribbon
- Inspection options including label presence detection and barcode scanning

Product Conveyor	Dual Side Belts
Dimensions	Length: 65" Width: 52" Height: 61"
Conveyor Elevation	Adjustable from 35" to 42"
Air Requirements	1 CFM at 80 PSI
Electrical	220 VAC, 60 Hz, single phase

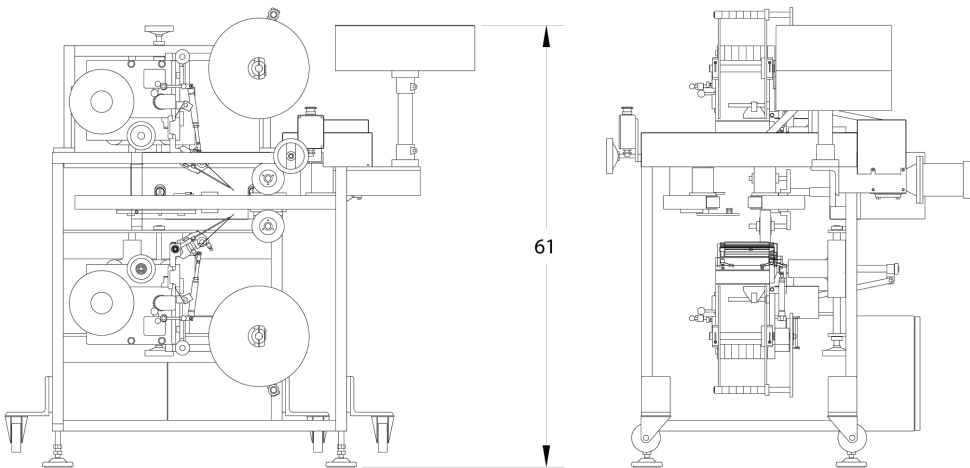

** Production rate indicated is subject to change, depending upon product and label combinations. All specifications and tooling requirements are subject to Accraply evaluation of all label and product samples. Specifications shown reflect standard machine capabilities. Accraply can also meet other specification requirements. Please call for details.*

Accraply | Trine | Stanford | Graham & Steevit | Harland

Accraply

9350 W Broadway Avenue, Suite 190
Minneapolis, MN 55445 USA

+1 (763) 557-1313
accraply.com