

Vial & Microtube Labeler

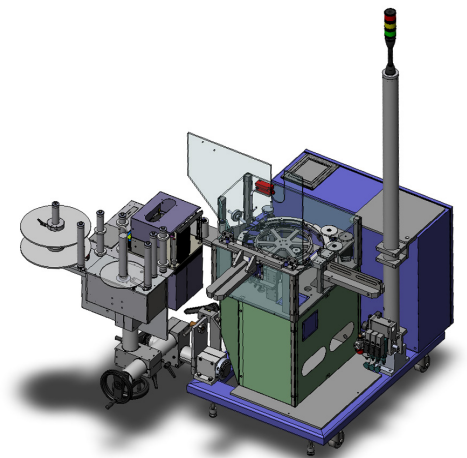
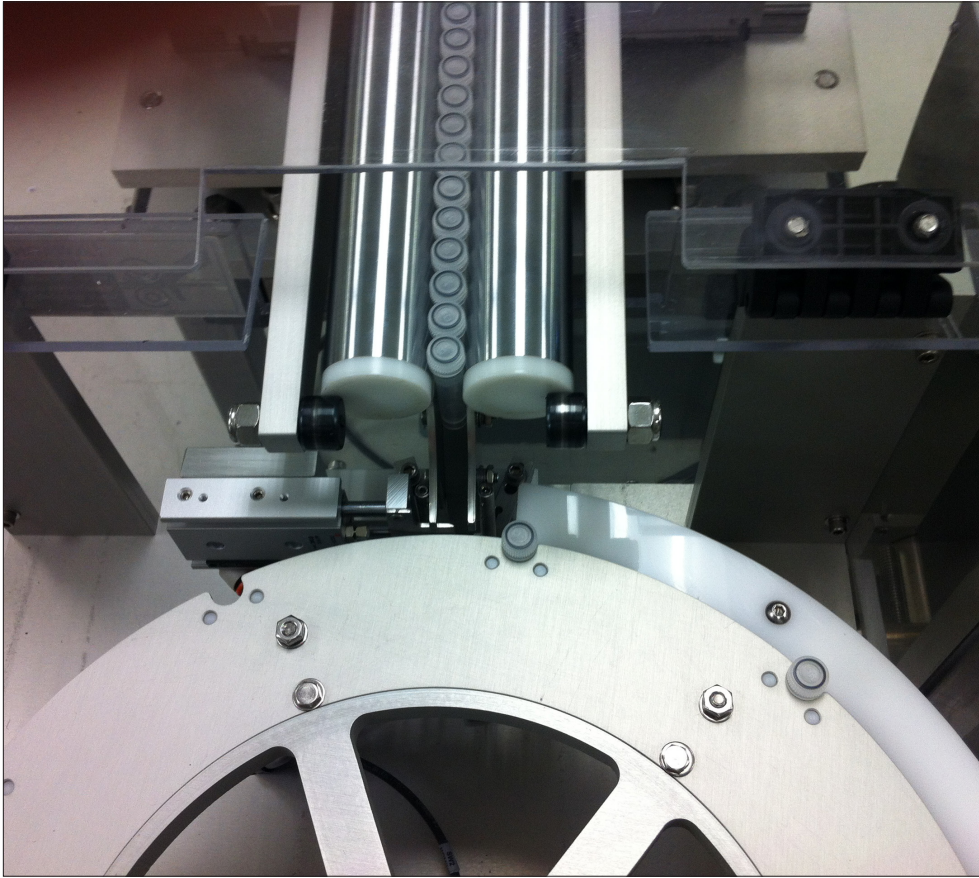

Features

- Microtube/vial labeling at speeds up to 60 per minute with a high degree of precision
- Servo-driven indexing dial with multiple stations for product infeed, wrap labelling, cap labelling, vision inspection, product eject and outfeed
- Print and apply labeling using the latest in thermal transfer print technology for the entire label
- 2D and 3D parcode printing capabilities
- Allen Bradley PLC with touch-screen controls
- Low label, low ribbon and system error alarms
- Counters or scales on all adjustments for accuracy and repeatability
- Backed by Accraply's "Gold Standard of Service"

Accraply Vial & Microtube Labeler

For 50 years Accraply has designed, engineered and built high quality labeling systems to help our customers meet their labeling demands.

Designed specifically to apply full or partial wrap labels to vials/microtubes that would not be stable when transported on a conveyor. Each pocket on the dial has two integrated rollers to side reference the product. The wrap roller provides a third point of contact, which virtually eliminates label skew. With multiple stations around the dial a number of processes can take place simultaneously such as labeling the top of the cap, product/label inspection and product eject. The dial indexing motion is servo driven with few mechanical components to provide accurate stop position and reduce maintenance. Dials are easily interchangeable to accept a range of product diameters and heights. Accraply provides a wide range of options and can build to suit your specific requirements.

Options

- Additional dials for additional product sizes
- BarTender label design software
- Datamax, Novexx, Markem and VideoJet printers
- Model 204 tamp/blow labeller for application of cap labels
- Anti-spin side belt allows ink jet printing on the cap of the microtube/vial
- Vision systems for label inspection and barcode/2d code verification
- Serialization for track and trace
- Micrometer rollers allow microtubes/vials to be fed to the system back to back
- Validation documentation including Functional/Design specifications, FAT documentation and IQ/OQ protocols

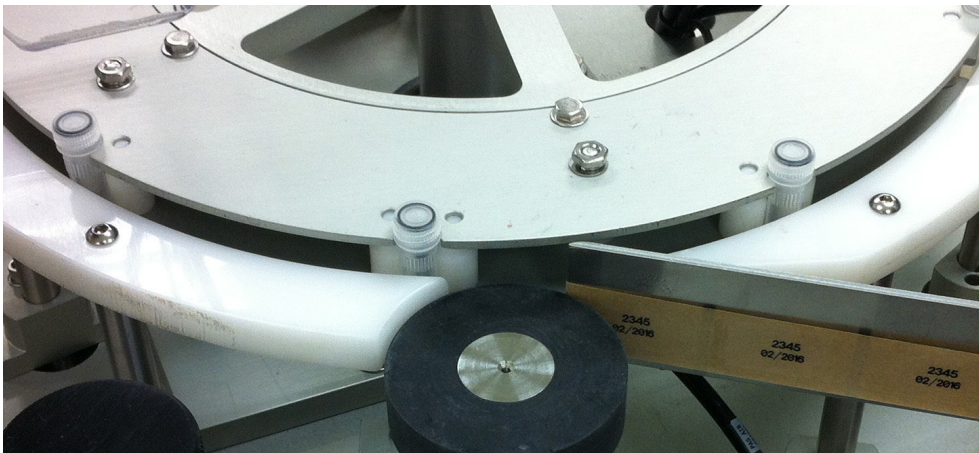

Accraply's Gold Standard of Service

"We commit to deliver the highest level of customer care, driven by our passion to provide the best customer experience in everything we do."

Accraply is a leader in the design, manufacture, and support of automated label application systems as well as converting and finishing equipment for the shrink sleeve label and flexible packaging markets.

Label Printer

Print Technology:	Thermal Transfer
Print Engine	Zebra & Sato
Print Resolution:	203, 305 or 609 dpi (model dependent)
Maximum Print Width:	Zebra- Up to 6.6" (167mm) Sato- Up to 6" (152 mm)
Print Speed:	Up to 16 ips
Output Mode:	Batch
Communication:	Ethernet & Serial (RS232)
Print Characteristics:	Selection of fonts including OCR- A & B (all commonly used) Barcodes 2D Codes
Print Rotation:	360 degree rotation
Label Design:	Bartender, LabelView, Nice Label, Lofware

System Specifications

Product Height:	40 mm (1.5") to 80 mm (3.14")
Product Diameter:	10 mm (0.39") to 30 mm (1.18")
Label Size:	Maximum Height: 50 mm (1.9") Maximum Length: 95 mm (3.7")
Speed:	Up to 60 per minute
Applicator Options:	Wrap and Top

General Specifications

Supply Voltage:	120VAC- 15 amps
Environment:	41°F (5°C) to 95°F (35° C), 45-75% Non-condensing humidity
Approval Rating:	CSA-UL recognized CE Available

Accraply | Trine | Stanford | Graham & Steevit | Harland

Accraply

9350 W Broadway Avenue, Suite 190
Minneapolis, MN 55445 USA

+1 (763) 557-1313
accraply.com