

# Trine 4400 Labeling System



## Features

- Efficient glue wheel transfer to minimize glue consumption
- PLC controlled for reliability and ease of operation
- Quick change components reduces changeover time
- Fewer moving parts reduces maintenance cost
- Industry's strongest field service organization reduces downtime
- Small footprint takes up minimal space
- Accraply quality and performance you expect

# Trine 4400 Roll-Fed Labeling System

## Compact Design with High Speed...

The 4400 roll fed wraparound system has been designed with a 30% smaller footprint than our previous machine while providing labeling speeds up to 200 cpm. Equipped with quick change parts, a product changeover can take one person less than 20 minutes guaranteed with just a single tool. To provide precise label application the 4400 is designed with the latest in glue application technology and label registration control. With advanced technology, quicker changeovers, and affordable change parts, the 4400 provides a roll fed labeling system ideal for any demanding environment.

With applications in beverage, food, pharmaceutical, cosmetic, dairy, aerosol and nutritional product industries, Trine roll fed labeling systems have proven their versatility. Trine roll fed labelers provide ongoing savings by replacing higher-cost cut labels. Additionally, Trine systems can even be used to label contour containers with Trine's patented Roll 'n' Shrink technology. With over 2000 systems currently labeling brands such as Coke and Pepsi, you too can rely on Trine labelers.

## Options

- Automatic flow control
- Air-conditioned electrical enclosure
- Electronic web tracker with tension brake system and ultrasonic sensor
- CE-Certified upgrade
- Alternative voltages, conveyor heights, and colors
- Additional options available. Contact an Accraply representative for more information.

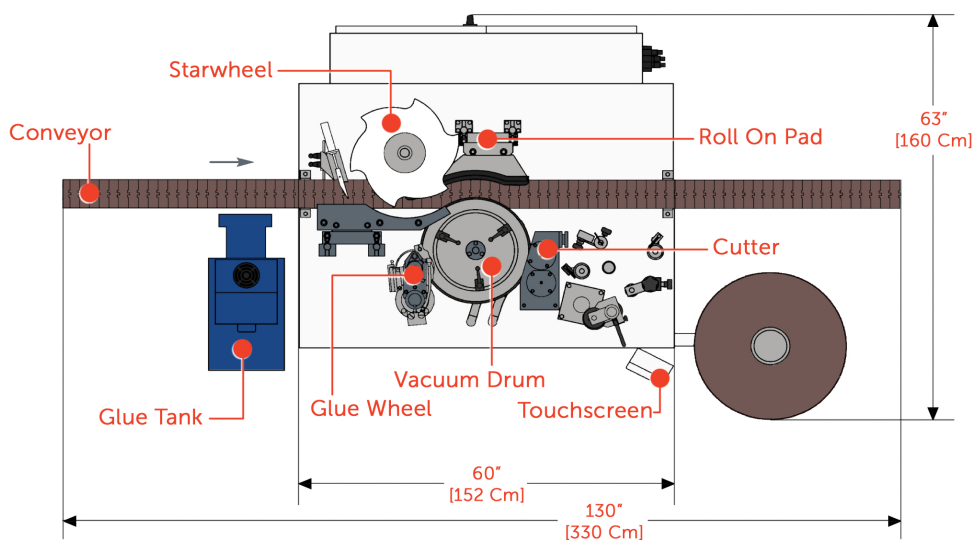

Maximum Speed:	200 Containers per Minute
Repeat Length:	6.5" to 16.5" [1.53.4mm to 419.1mm]
Web Width:	1" to 8.25" [25.4mm to 209.6mm]
Diameter:	1.75" to 5" [44.5mm to 127mm]
Air	80 psi (5.52 bar), 12-15 cfm (340-425 L/min)
Electrical:	240 VAC, 3-Phase, 50/60hz
Weight:	3,200 lbs [1,451 kg]

*\* All specification and tooling requirements are subject to Accraply evaluation of all label and product samples. Specifications shown reflect standard machine capabilities. Accraply can also meet other specification requirements. Please call for details.*

## Accraply's Gold Standard of Service

"We commit to deliver the highest level of customer care driven by our passion to provide the best customer experience in everything we do."

Accraply | Trine | Stanford | Graham & Steevit | Harland

## Accraply

9350 W Broadway Avenue, Suite 190  
Minneapolis, MN 55445 USA

+1 (763) 557-1313  
accraply.com

